

Design and Development of a Low Cost Signal Conditioning and Fast Data Acquisition System for Detection of Secondary Cosmic Rays

Shakeel Zama^{1*}, Nipan Das^{2#}, Kalyanee Boruah^{3*} and Pradip K. Boruah^{4#}

^{*}Dept. of Physics, Gauhati University

[#]Dept. of Instrumentation & USIC, Gauhati University

E-mail: ¹shakeelz123@rediffmail.com

Abstract—A simple and low-cost signal conditioning and data acquisition system has been developed for use in cosmic ray shower particle detection experiment consisting of four plastic scintillation detectors, positioned at the corners of a square array. The experiment is aimed at recording the pulse height and the time delay at each detector individually. Scintillation blocks are viewed by photomultiplier tubes (PMT) and the analogue pulses from the PMTs are amplified by preamplifiers. A discriminator selects a genuine pulse from the ambient electromagnetic noise and converts it into a digital pulse, which is finally shaped by a pulse shaper into suitable width. Counters based on 8051 microcontroller are employed to automatically count the particle arrival rate; and the data are recorded in a personal computer for analysis. Count rate of cosmic ray particles at the ground level, for each scintillation detector channel has been found to be in agreement with theoretical expectation.

Keywords: signal conditioning, data acquisition, photomultiplier tube, scintillation detector, cosmic rays, discriminator.

1. INTRODUCTION

The charged particles and gamma rays that strike air molecules at the top of the atmosphere from outer space are called primary cosmic rays. The inelastic collision produces secondary particles, which initially, are predominantly hadrons. Due to their transverse momenta the hadrons spread out laterally.

Subsequent collisions with air molecules, as well as decay of hadrons, produce particles such as muons, neutrinos, electrons, positrons and gamma-photons, which reach the surface of the earth along with nucleons [1]. Primary cosmic ray flux with energy $E > 10^{14}$ eV is very low; and they are usually detected indirectly by ground based detectors with the help of the secondary particles spread over several square kilometers on the ground, called Extensive Air Shower (EAS). Muons are the most abundant secondary charged particles at the ground level [2]. Among others, plastic scintillation detectors can be effectively used to detect the secondary particles [3]. When a charged secondary particle passes through a scintillation

block, the molecules in the scintillator are excited. The de-excitation of these molecules produce visible or UV photons. When these photons strike the photocathode, photoelectrons are produced, which are multiplied in the PMT dynodes. Thus the PMT converts the electromagnetic pulse into an electrical analogue voltage pulse lasting a few nanoseconds [4]. These analog pulses contain critical information about the nature and the origin of an EAS.

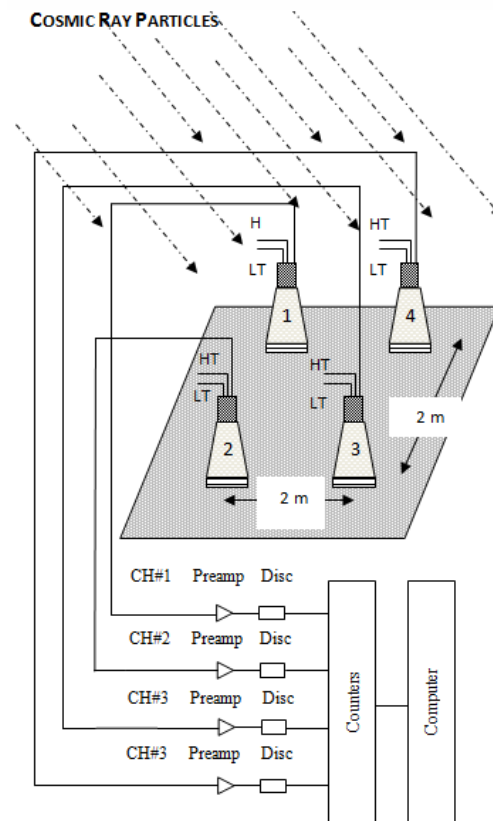

Fig. 1: The prototype array and the DAQ system

Arrival of an EAS may be recorded by the method of coincidence among the pulses from a number of scintillation detectors spread over a horizontal area and triggered simultaneously. For this purpose, the analog pulses from the PMTs are to be converted into digital signals. This is accomplished by using a discriminator circuit, comprising a comparator with adjustable voltage threshold. The discriminator produces a standard digital output only when the input pulse height exceeds the threshold level. The digital signals are, in turn, fed to a digital logic circuit, to generate a trigger to record an EAS.

The signal conditioning circuit for the four detector channels deployed in the present air shower array consists of pre-amplifier, discriminator and pulse shaper, designed for the purpose. The conditioned pulses from the detectors are counted automatically using 8051 microcontroller based data acquisition system. The present paper discusses the design considerations of the signal conditioning circuits and the data acquisition system.

2. DESCRIPTION OF THE ARRAY

A small prototype square array of four plastic scintillation detectors is set up at the first floor of the Department of Physics, University of Gauhati in Guwahati (26.1537° N, 91.6634° E, $55.5 \text{ m} \cong 1023 \text{ g cm}^{-2}$), with the aim to study the atmospheric effects by measuring the zenith angle distribution from the recorded arrival times at each individual detector [5]. The four detectors are arranged in a square of area $2\text{m} \times 2\text{m}$ (figure1). Each detector consists of a plastic scintillation block (Bicron BC-416), of dimensions $50 \text{ cm} \times 50 \text{ cm} \times 5 \text{ cm}$ and a PMT.

The individual detector channels are adjusted using suitable discriminator levels and count rates are recorded by a standard NIM bin single counter-timer (EC 5104) and also by the 8051 microcontroller based counters and the data acquisition system designed for the purpose. It has been estimated that, on an average, 1 secondary particle hits roughly 1 sq cm area of the ground per minute [6,7]. Therefore, approximately 40 numbers of particles are expected to pass through a horizontal scintillation block of surface area $50 \text{ cm} \times 50 \text{ cm}$ per second. In the present set up the PMT voltages and the discriminator levels are so adjusted that around 40 number of pulses are recorded per second in the counters. At the time of writing, several hours of cosmic ray particle counts have been recorded for each of the 4 detectors in the prototype array. The data recorded by the designed system shows close agreement with those recorded by a standard NIM bin single counter- timer.

3. THE DATA ACQUISITION SYSTEM

In the prototype array, the scintillator blocks are laid horizontally, housed in pyramidal aluminum box of height 85 cm. Facing each scintillator block is a 5 inch diameter photomultiplier tube (Du Mont 6364) with grounded cathode.

The whole assembly is made light-tight with the help of black PVC sheets. The PMTs are operated from two EHT modules (HV 216D and HV 502) inside a NIM bin (Electronics Corporation of India Ltd.). The necessary voltages to the four PMTs are provided through a high voltage distribution box, which gets input from the two HT modules, each set at around 1.8 kV.

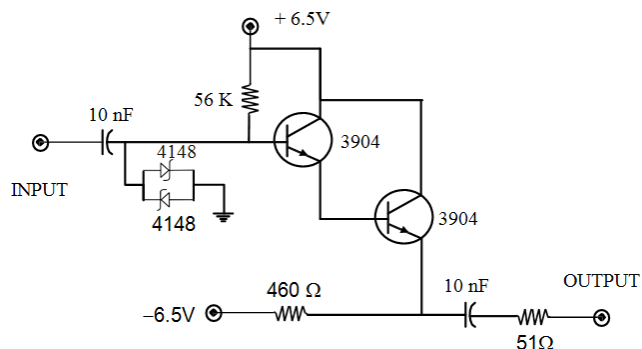

Fig. 2: Schematic of the preamplifier circuit.

The signals from the PMTs are amplified by a preamplifier, which is basically a Darlington pair using two NPN transistors (2N 3904). A dual power supply unit (Scientech ST 4075) provides $\pm 6.5 \text{ V}$ steady voltages to the preamplifier.

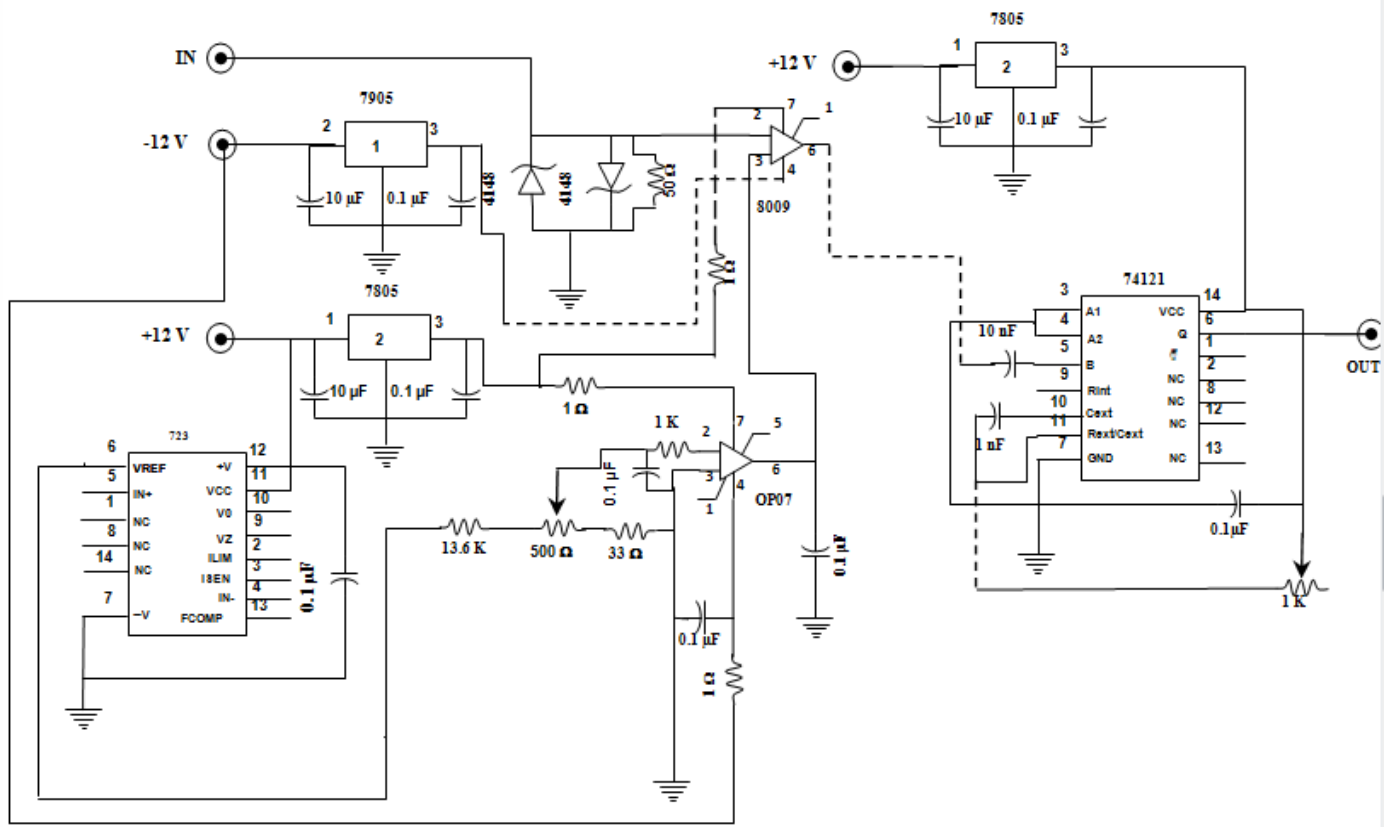

Fig. 3: Schematics of the discriminator and the pulse shaper circuits

The output pulse of around 200mV from the preamplifier is fed into a four channel discriminator and pulse shapers through co-axial cables (RG 58U). One channel of the discriminator and the pulse shaper circuits are shown in fig. 3. The discriminator output logic pulse of 600 ns width is displayed by a 100 MHz two channel digital storage oscilloscope (Textronix TDS 1012B). The pulse rate for each channel is measured, first with the single counter-timer in the NIM bin, and then with the help of the 8051 microcontroller based counters. For recording the counts, counter 0 and counter 2 of microcontroller P89V51RD2 [8] is configured in 16-bit mode. The micro controller is connected to PC by RS232 communication at 9600 baud rate. An algorithm is developed for counting the pulses by the two counters simultaneously at an interval of 10 seconds and sending the data to PC in proper format. The developed algorithm is implemented in the microcontroller by writing suitable C-code in Keil-μ Vision 4 IDE (Integrated Development Environment) [9]. To log the received data in a PC, a program is developed in C language using Turbo C++ IDE. Data are stored in PC in EXCEL format along with records of date and time.

4. EXPERIMENTAL RESULTS

The particle count rate from each channel has been taken with the help of the NIM bin counter-timer. The average count rates for channel number 1, 2, 3 and 4 are found to be (40 ± 1) , (40 ± 1) , (41 ± 1) and (41 ± 4) particles per second respectively. The count rates for each channel were then taken with the help of the micro-controller based counters. Around 6 hours' of logged data are plotted as shown in fig. 4 and 5.

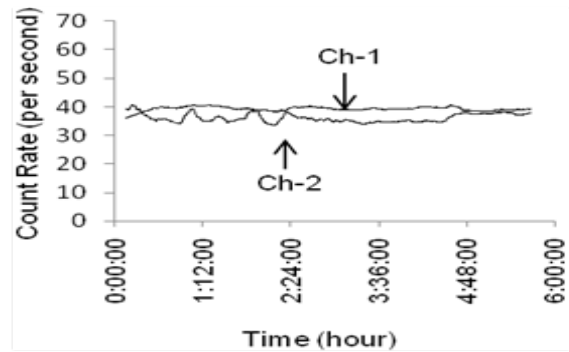

Fig. 4: Particle count rates for ch-1 and ch-2

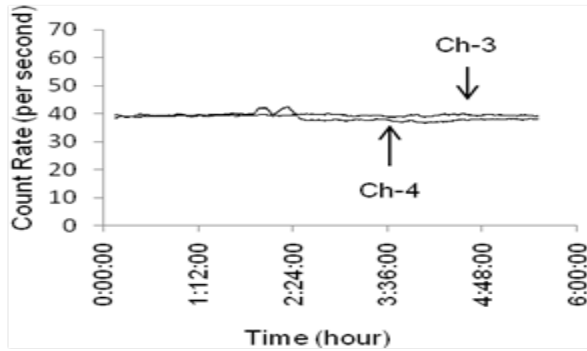

Fig. 5: Particle count rates for ch-3 and ch-4

The relative fluctuations of count rates for the four channels are respectively 7.5%, 7.4%, 5.0% and 6.12% counts per second.

5. CONCLUSION

The four curves in fig-4 and fig-5 show that the microcontroller based counters give count rates of approximately 40 per second for each of the channels. However, there are some jitters in channel-2 and channel-4. These could be due to fluctuations in the EHT supplied to the PMTs and spurious pulses picked up by the system. The present DAQ system has the added advantage of operating automatically compared to the conventional manual method.

REFERENCES

- [1] Grieder, Peter K. F. Extensive Air Showers: High Energy and Astrophysical Aspects, A Tutorial, Reference Manual and Data Book, Springer-Verlag Berlin Heidelberg, **1**, 2010, pp 3-4
- [2] Grieder, Peter K. F., Cosmic Rays at Earth: Researcher's Reference Manual and Data Book, Elsevier, Amsterdam-London-NewYork-Oxford-Paris-Shannon-Tokyo, 2001, pp 305
- [3] Stanev, T., High Energy Cosmic Rays, Springer- Verlag Berlin Heidelberg New York, 2010, pp 192, 235-239
- [4] Gupta, S.K., et al, "A High Performance, Low-cost, Leading Edge Discriminator, *Pramana*, **65**, 2, 2005, pp 273-283
- [5] Bahmanabadi, M., et al, "A Study of the Effect of Geomagnetic Field on Extensive Air Showers with Small Arrays", *Experimental Astronomy*, **13**, 2002, pp 39-57
- [6] Cosmic Rays-Particle Data Group <http://pdg.lbl.gov/2011/reviews/rpp2011-rev-cosmic-rays.pdf>
- [7] Cecchini, S., Spurio, M., "Atmospheric Muons: Experimental Aspects", *Geosci. Instrum. Method Data Syst.* **1**, 2012, pp 186-196
- [8] http://www.nxp.com/documents/data_sheet/P89V51RB2_RC2_RD2.pdf
- [9] www.keil.com/uvision